

9186S
automatic tape dispenser

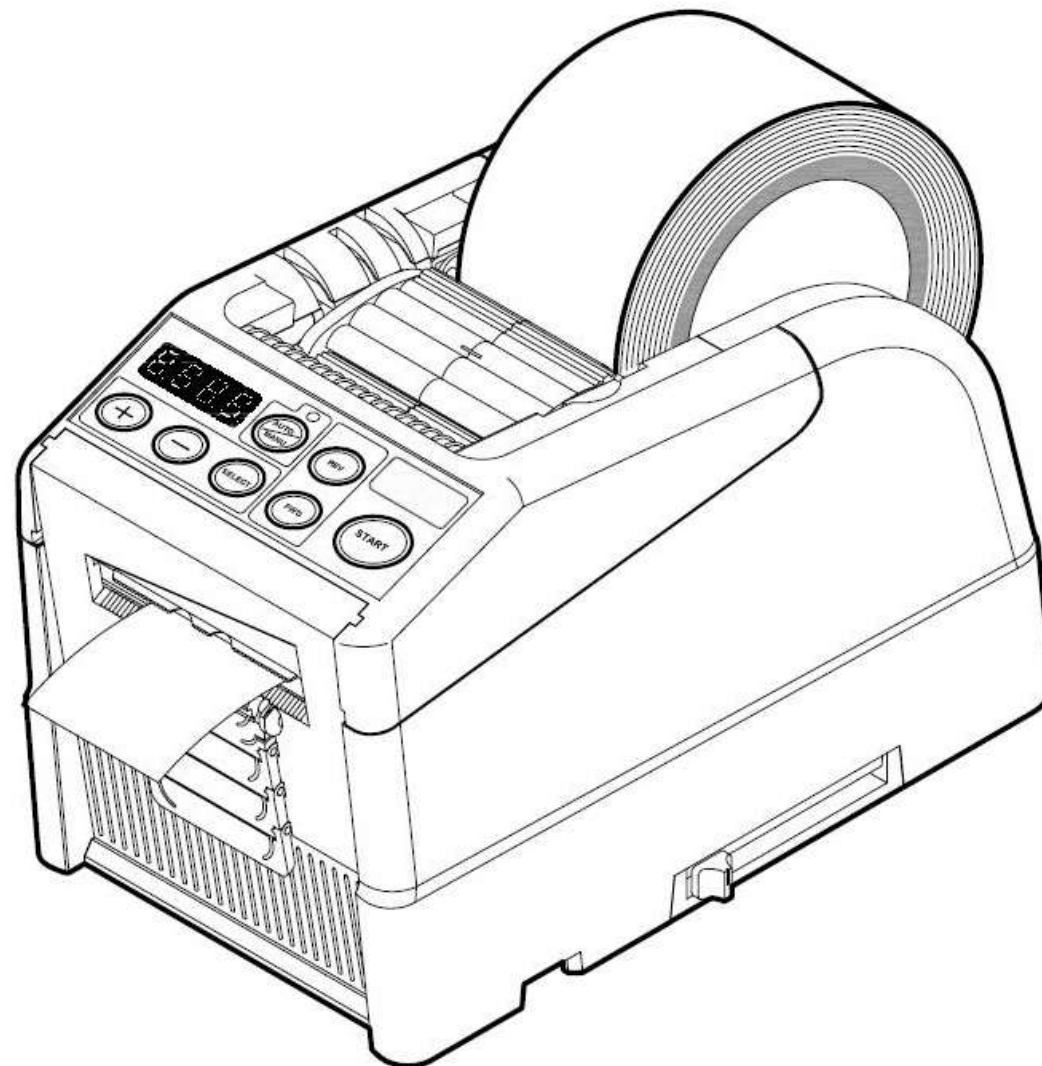

Before use

Please read the manual before start using the product

Thank you for purchasing Auto Tape Dispenser 9186.

9186 is a compact, unique feeding system which allows to many kinds of tape, includes minimum size of thin tapes.

Please read this Instruction Manual carefully. For your safety, please keep this Instruction Manual for reference, retraining and trouble shooting.

Contents

P2	Before Use
P3	Safety Instructions
P3-4	Definition of Warning and Caution Symbols
P5	Identification of Parts
P6	Loading the Tape Roll
P7	Setting the Tape Length
P7-8	Setting the Modes
P9	When using a tape easily curling up
P9	When using two tapes / Other functions
P10	Replacing the Cutter Unit/ Checking the Unit
P11	Checking & Replacing the Roller
P12	Error Message
P13	Malfunction
P13	Specifications
P14-15	Parts Breakdown

Environment conditions

Parameter	Symbol	Min	Max	Unit
Operating temperature	Topr	0	+40	°C

Safety instructions

The safety guidelines in this Instruction Manual must be observed in order to prevent damage to the machine or injury to the operator or other person. The safety guidelines prescribed "Warning" and "Caution" describe possible injury or damage that may be suffered from operating or maintaining the machine in a manner other than as described in this Instruction Manual.

Read and follow the safety precautions carefully before reading the Instruction Manual.

Definition of warning and caution symbols



Warning Indicates a potentially hazardous situation which if not avoided, could result in death or serious injury



Caution Indicates that carelessness of handling may result in danger and that the operator is at risk of injury, or the machine is at risk of damage.



Indicates Caution

A symbol within the triangle, or the description, will indicate a specific hazard



A Prohibited Action

A symbol within the circle, or with a diagonal stroke, will indicate prohibited action.



A Required Action

A symbol within the circle in black, or the description, will indicate the required action.

Warning



Do not plug in, unplug the cord, or operate the machine with wet hands. Failure to observe this may result in injury due to electric shocks.



Never insert your finger, or any other body part, or any foreign object into the machine. Failure to observe this may result in injury.



Keep hair or loose clothing away from the machine while it is operating. Failure to observe this may result in injury.



This machine is intended for industrial use only. Do not allow untrained operators or children to operate the machine. Failure to observe this may result in injury.



Turn off the power switch and unplug machine prior to replacing the blade or performing any maintenance the machine. Failure to observe this may result in serious injury.



Do not use this machine for anything other than its specified applications. Use of the machine for any unintended applications can cause injury to the operator or failure of the machine.

Caution



Do not install the machine where it is wet. It may cause electric shock or damage to the product.



This machine must not be disassembled or remodeled. It may cause accidents or breakdown of the product.



When you unplug the product, hold the plug. If you pull the cord, it can cause shock or electric shock due to snapping of the wire.



Do not put waste into the label outlet. It may cause accidents or breakdown of the product.



Professional should stay by the machine at all times while it is running. When the machine is left unattended, make sure to turn it off and unplug it. It may cause accidents or breakdown of the product.



Put in the power plug tightly. If it is not plugged in tightly, it may cause fire due to contact failure

Identification of parts

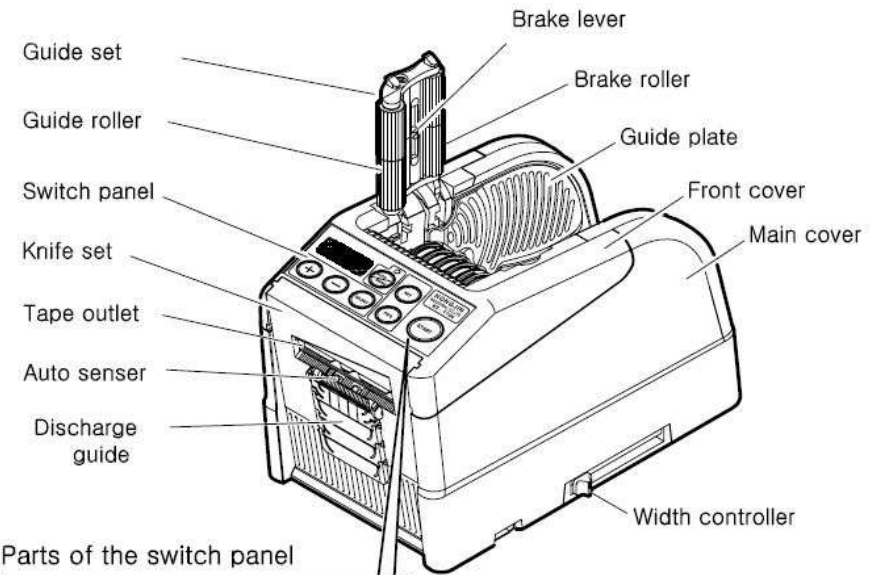

Parts of the switch panel

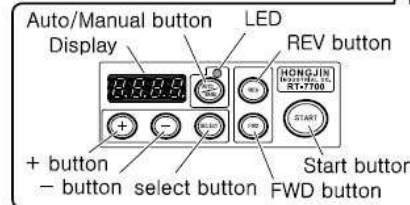

Lower part of product

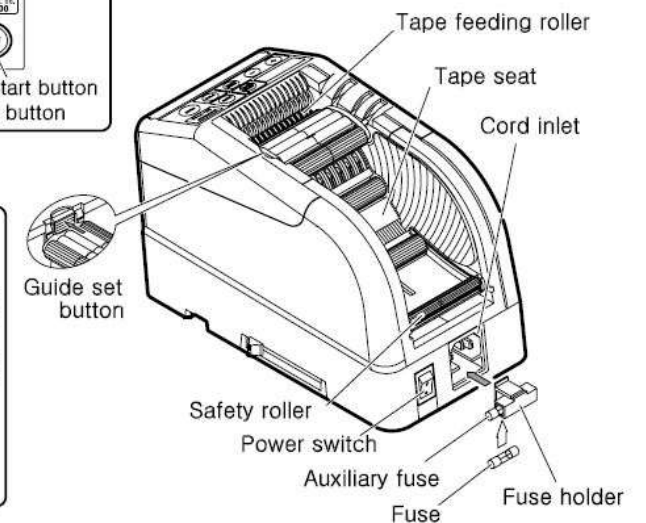
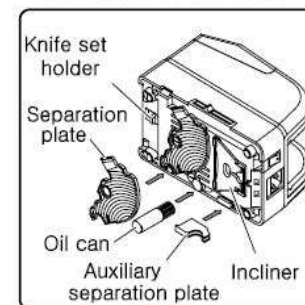

Loading the tape roll

- Insert the AC cord into the inlet of the main body.
- Plug in the earth terminal.
- Turn off the product and plug in.
- Turn on the product.
- When turned on, the product begins to make a sound while the length to cut tape displayed.
- When turned on, the product is manual.
- Open the guide set by pressing the guide set button.
- Put tape on the tape seat.
- Adjust the guide plate by moving the width controller.
- The guide plate touching the side of tape, move the controller back a bit so that the tape rolls smoothly.
- When mounting a wide tape, pull the safety roller enough so that the tape does not fall.
- Mount the tape with the glue side down under the guide roller.
- Press the FWD until the tape is out of the outlet.
- In case of a highly adhesive tape, roll it out enough before mounting it and pressing the FWD.
- The FWD button is operated only while pressed. Setting the tape, adjust the length of time it is pressed so that the tape moves little by little.

For your safety, the guide roller operates slowly until the tape reaches the outlet. Then, it begins to operate at a normal speed.

- Close the guide set once the tape is fully mounted.
- Press the start button.
- If the start button is pressed right after the FWD, the cutter cuts the tape out of the outlet. Please remove the part of the tape cut. Set the product according to the next page and press the start button, and the product begins to operate at a mode set.



Be sure the glue side of the tape looks down when mounting the tape. Otherwise, the tape might not roll smoothly.

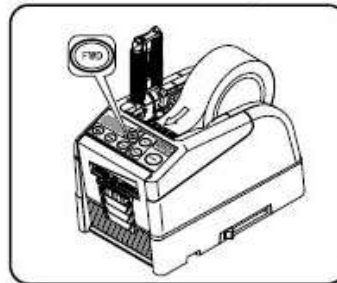
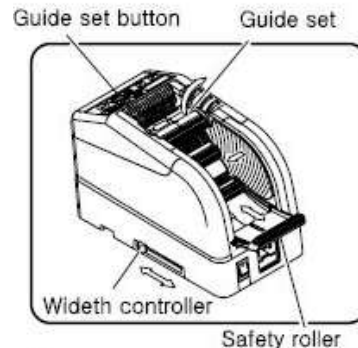
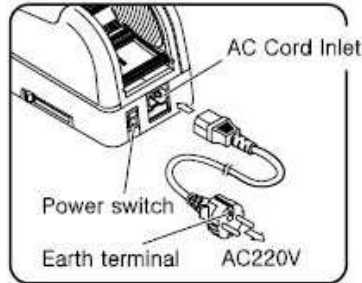

Setting the tape length

- Check if the length you want is displayed.
- The length to cut tape is displayed with A to F and numbers.
- Set the length to cut tape.
- Set the length by pressing the + or - button.
- With this product, you can set 6 types of length. Select one among A to F by pressing the Select button short and set the length to cut tape. (cut range: 5mm to 999mm)
- Basic length is set like the following - A : 30, b : 40, c : 0, d : 0, E : 0, and F : 0
- 1mm increases or decreases every time the + or - button is pressed short. Pressed long, 5mm.

Setting the modes

This machine has the following 4 functions.

A user of this product can do various works by setting a mode desired.

Auto/manual mode

The Auto/manual button push briefly and please switch to an automatic mode or a passive mode.

- Because it is switched to a Program mode if push the button more than 1 sec, please be careful.

Manual mode (LED off)

- Check the LED is off.
- If the LED is on or blinking, please turn off it.
- Pressing the Start button cuts the tape once. Then the unit standby.

Auto mode (LED on)

- Check the LED is blinking.
- If the LED is off, press the Auto/manu button briefly to make the LED blink.
- Pressing the Start button cuts the tape. Then the unit standby.
- Check if the LED is on when cut tape waits in the Tape outlet.
- Removing the tape standing by at the Tape outlet, the unit automatically cuts the next part of the tape and standby.

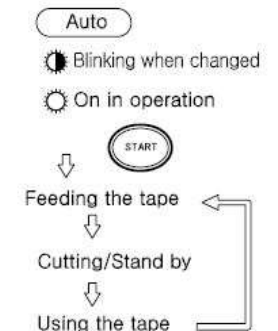
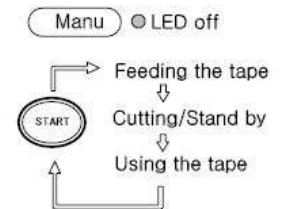
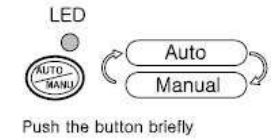
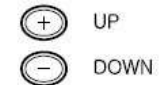
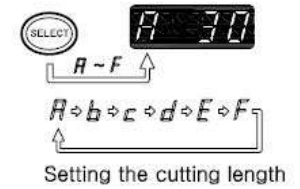

P mode (countdown mode)

Cutting the number of tape set is finished, the buzzer informs you. This mode is available automatically and manually. Setting is available up to 999.

- Select desired cutting length (A to F) by pressing "Select".
- Push the Select button more than 1 sec, Leon is displayed.
- The Select button push briefly again, P mode is on.
- P is shown on the display.
- Set the number desired by pressing the +/- button.
- Select the mode by pressing Auto/manual button.
- Pressing the Start button cuts the tape and the unit standby.
- Every time the tape is out, the number of cuts remaining is displayed.
- When 0 is displayed, the buzzer alarms.
- After the buzzing, the number set first is displayed.
- At the automatic mode, remove the tape after the buzzing.
- Removing the tape before buzzing, the LED begins to blink.
- Then, press the Start button to move and cut the tape.
- Press Auto/manual button to change mode while processing.

Checking the cutting length

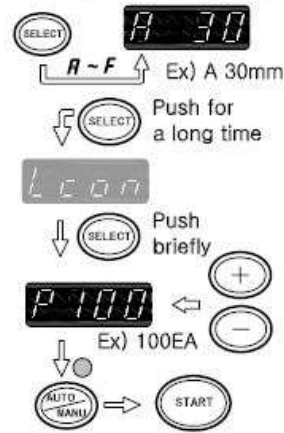

L mode (consecutive cutting modes)

Setting the number and pressing the Start button, the unit operates without stopping until the program is over and the unit buzzes. Setting is available up to 999.

- Select the cutting length desired (A to F) by pressing the Select button.
- Push the Select button more than 1 sec, Lcon is displayed.
- Set the number desired by pressing the +/- button.
- Pressing the Start button, the unit cuts the tape repeatedly displaying the number.
- When 0 is displayed, the unit buzzes and stops.
- After the buzzing, the number set first is displayed.
- If the unit needs to be paused, press the Start button.
- If the tape needs to be cut regardless of the number, press the Start button with Leon displayed.

Checking the cutting length

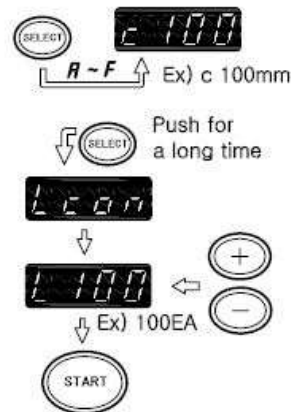

Program mode (sequentially cutting mode)

This mode cuts tape in order programmed beforehand.

- Push the Auto/manual button more than 1 sec, the first segment of the Display is marked with a dot and the Program mode is on.
- Cutting by up to six kinds other lengths is available.
- The length of the tape cut is displayed on the Display.

Checking the cutting length

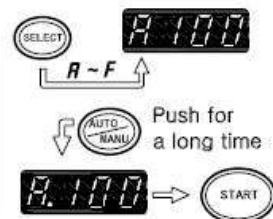

P mode (countdown mode)

- Raise the guide set by pressing the guide set button.
- Widen it by pushing the brake lever of the guide set.
- Close the guide set.
- When the tape is curled up despite using the brake roller, hold it stronger while using the width controller.
- The lengths of cutting and setting might be different depending on the type of tape or conditions of use.
- Then measure the tape cut and correct the difference.

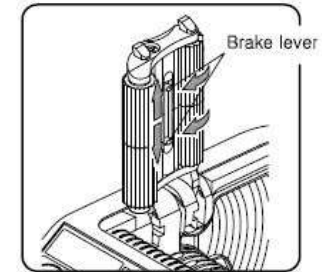

Auxiliary separation plate

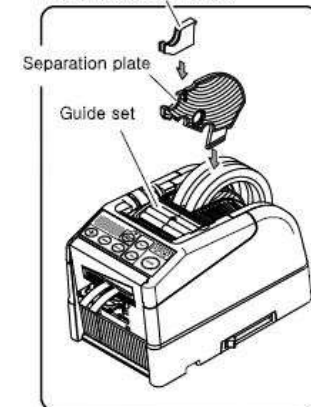

When using two tapes

Insert the separation plate when using the tape below 10mm wide. It is possible to use 2 tapes below 25mm wide at the same time.

- Take out separation plate under the main body.
- Raise the guide set by pressing guide set button.
- When using a tape below 10mm wide, insert the auxiliary separation plate under the main body and insert it into the separation plate.
- Take out the auxiliary separation plate under the main body and insert it into the separation plate.
- Put the tape on the tape seat and adjust guide plate by moving the width controller.
- Install the tape and set the mode desired.
- When two tapes are used at the automatic mode, removing both tapes at the outlet makes the next part of the tape stand by.

**Caution: Using two highly adhesive tapes forcefully might affect the motor and reduces its life span.*

Other functions

Discharge guide plate

Adjust its angle depending on tape or Process. Connection use is possible for long.

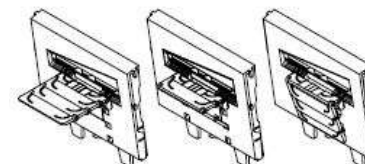

Incline prop

Open to incline main body depending on tape or process.

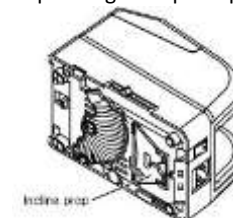

Replacing the cutter unit



There is a risk of accidents.

Before replacing, turn the power off and disconnect the power plug.



The blades are very sharp.

Careful to avoid touching the blade area.

The cutter unit is a consumable item. Replace the cutter unit if cutting condition worsens.

- Turn off the product first.
- Raise and separate the Cutter unit by pulling the cutter holder to the front.
- Check if lower side of the new cutter is parallel to outlet.
- If not, push it up to lower end by using a screwdriver.
- Insert cutter into the main body and press hard to fix it.

Checking the unit

Washing the cutter

Some tapes might cause glue or tape fragments to stick to the cutter. In this case, remove the cutter from the main body and wash it.

- Turn off the product and remove the cutter.
- Remove sticky material with alcohol and dry cloth or a swab.
- Install the cutter.

Lubrication of the cutter

For smooth operation of the product, regular lubrication is needed.

- Turn off the product and remove the cutter.
- Put some oil into the lubrication hole of the cutter.
- Put some oil into the guide rail of the lower blade.
- Install the cutter unit.
- Wash off overflow oil. Be sure the oil doesn't overflow.
- Do not forget to test drive before using the product.

Around the auto sensor

The product cannot detect the tape if the sensor under the tape outlet is dirty.

- Always keep the sensor clean
- Be careful not to scratch the sensor in removing the tape fragments on it.

Washing the main body

Wipe the main body gently with the water containing some diluted neutral detergent. Never use organic solvents.

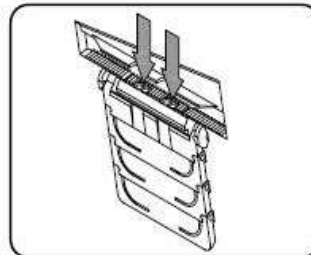
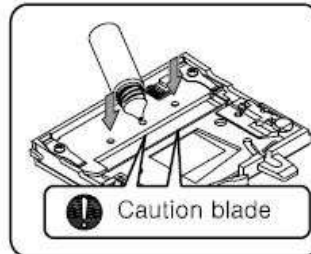
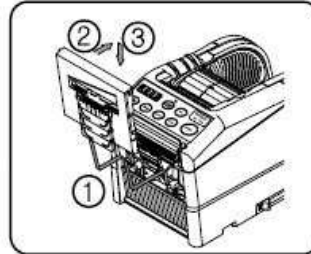
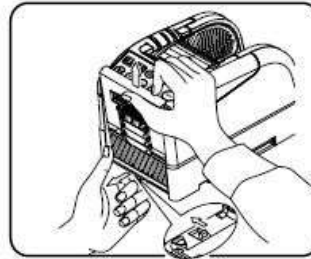

Checking and replacing the roller

The roller which is damaged or cannot be used any more can be easily exchanged. Refer to the following when the tape is stuck at the outlet or not rolled out smoothly.

- Turn off the product first.
- Pull cutter holder to the front and raise the cutter unit to remove it from the main body.
- Using both hands as shown in the figure, the front cover and pull as hard as the front, then unlock and lift up to 90° rotation.

Front board enter the Safety switch is activated, the front board and the front cover is opened, the power is automatically turned off.

- Remove front board in upper part of the body.
- Open guide set by pressing guide set button.
- Guide set; the front frame of the lock is released.
- The front frame set is separated from the main body.
- Up the front frame set to lift body from exit.
- Large roller set, slide it toward the back to remove it from the front frame set.
- Remove guide bar from the front frame set.
- Loosening the screw in the bottom center of the back of the frame in front of the point, you can separate the left and right.
- Be sure to read not to change the position of the gear decomposition.

- Remove sticky material or tape fragments on the roller.
- If the roller is heavily damaged or worn, replace it with a new one.
- Put some oil to the spinning axes at both ends of the front unit.
- Install the roller part to the main body.
- Please check that each part of the combined correctly concluded.
- Locate the auto sensor unit to its initial place.
- Install the cutter unit.
- Insert cutter unit into main body and press hard to fix it.
- Test drive before using the product.

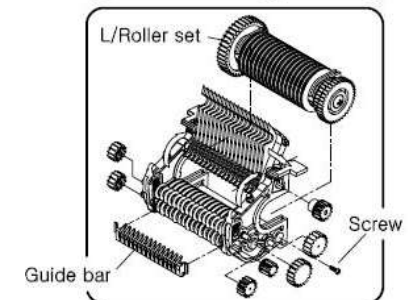
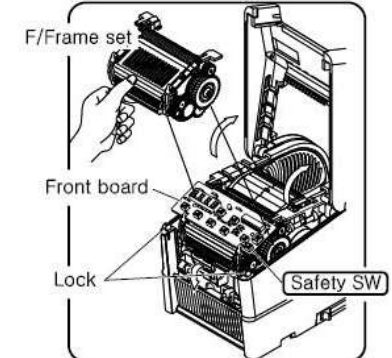
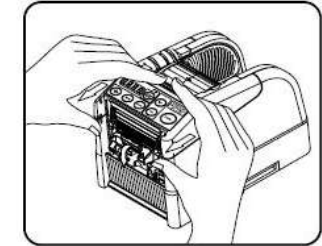
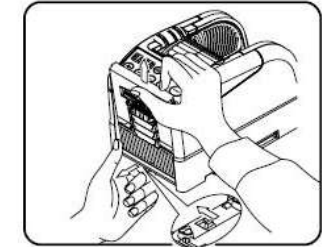

Error message

The product buzzing and stopping while used, the following message is displayed.

E-02 Cutter location error

It is shown when the tape is stuck in the cutter part, or the cutter is not correctly mounted in the main body.

- Turn off the product.
- Pull the cutter holder to the front and raise the cutter unit to separate it.
- Turn on the product.
- Press the Start button.
- (the cutter cam moves to the standby location)
- Press the FWD button and eject the tape. Then, cut the tape out of the guide bar with scissors.
- Press the REV button pulling the tape back to take it out.
- Clean the cutter set and put some oil to the lower blade guide.
- Mount the cutter unit to the main body.
- Install the tape according to the method mentioned before.

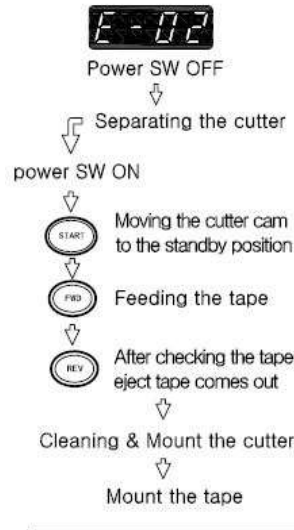

E-03 Motor stop

Sometimes, the motor could be overloaded and stop while feeding the tape.

- Cancel the error message by pressing the start button.
- Move the tape back by pressing the REV button and take it out.
- Check around the cutter or tape mover and remove the tape fragments and the like with tweezers.
- Install the tape according to the method mentioned before.

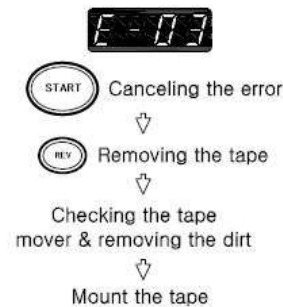

Be sure not to touch the blade when removing what caused an error.



If the product does not function even after following the above or if the product malfunctions without any error message, turn off the product and stop using it.



Do not use tapes which can cause thousands of volts of static electricity while use. Or there might be an accident.

Malfunction

Please check the following before deciding the product is out of order.

Not working with the power on.	<ul style="list-style-type: none"> AC cord disconnection. Fuse disconnection. 	<ul style="list-style-type: none"> Check if the cord is connected right. Replace the fuse to new one. If the fuse disconnection continues, stop using the product.
Next part of the tape not coming out even after removing one. (auto mode)	<ul style="list-style-type: none"> The manual mode is on. The sensor is dirty. The tape did not to through the sensor. There is a light source close to the sensor. A tape with an extremely low reflexivity is used. 	<ul style="list-style-type: none"> Set the automatic mode. Clean the product. When using a tape less than 10mm wide, please use the separation plate. Do not let the light source reach the sensor. There are some tapes not compatible with automatic mode.
Abnormal operation of the cutter	<ul style="list-style-type: none"> The cutter is installed wrong. 	<ul style="list-style-type: none"> Check if the cutter unit is correctly installed on the main body.
Difference between the actual length and the set one.	<ul style="list-style-type: none"> A highly adhesive tape is used. A slippery tape is used. An elastic tape is used. 	<ul style="list-style-type: none"> Test cut and correct the difference.
Tape curled up	<ul style="list-style-type: none"> The brake lever is not used. 	<ul style="list-style-type: none"> Use the brake lever.



If the product keeps showing disorder even after following those mentioned above, please stop using it and call the seller or the manufacturer.

Specifications*

Power requirement	AC100-240V Free Volt
Input voltage range	+/- 5%
Power consumption	25W
Dimensions	116mm x 140mm x 213mm (WxHxD)
Weight	2,3 kg
Material	Special ABS Resin
Cutting width*	6-60 mm (note 1)
Cutting length*	5-999 mm (note 2)
Moving speed	200mm/sec
Tape diameter*	Ø30 - Ø300 (note 3)
Accessories	Power cord, 2A fuse (extra 1pc built in AC inlet) separation plate & auxiliary separation plate, silicon oil can 3.5cc

* Note 1 to 3 might not be available depending on the type of tape and conditions of use.

* Parts may change without prior notification for product improvement. Please understand.

9186S Free-volt type

Auto tape dispenser

